



**Electrical Hazard:** Disconnect power from equipment prior to making any internal adjustments. Service should only be performed by qualified personnel.



**Fragile:** Inspect the equipment prior to installation. Do not install the equipment if damaged is apparent. Do not attempt to disassemble the equipment. If damaged, return to the supplier.



**Electrostatic Hazard:** This is sensitive electronic equipment. Apply safe anti-static practices when handling this equipment.

## General Description

The synchronisation function module can be used in the same area for multiple sounder alarm, strobe alarm, sounder / strobe alarm and so on through the simple 2 wire wiring to achieve synchronisation. The sound alarm signal can be independently controlled to start stop, the strobe alarm can continue to keep sync flash...

The module supports Class A and Class B wiring loop and can switch the Class B to Class A mode according to the online state automatically <sup>1</sup>, Class A need not use the EOL resistor <sup>2</sup>.

If there is an external power supply providing to the module, the module can expand the load capacity of the FACP NAC output, maximum quantity of the VDOT-SFM in the same zone is 8 pcs, please check the wiring diagram for details.

If the DC IN is reverse polarity, the VDOT-SFM will be no output, if the power input change to positive polarity and the VDOT-SFM in master mode, the VDOT-SFM will emit synchronisation power signal.

Module has an status indicator LED, if output over the current or NAC OUT wiring fault, the indicator LED will change from green to red flashing <sup>3</sup>.

**Note 1:** If the wire connection mode is Class A and in fault of the NAC OUT wiring loop occurred, the module will automatically switch B Class to A Class mode.

**Note 2:** The internal EOLR is 4.7k Ohm.

**Note 3:** If wiring fault occurred, the LED will flash in red colour every sync pulse, if the NAC OUT loop over current, the LED will keep light in red colour, and the NAC OUT will no output until the over current fault is clear.

**Product Specifications**

The following table is a VDOT-SFM parameter, the typical current does not contain the consume by EOL resistance and notification appliances.

Nominal Voltage	Regulated 24 VDC
Sync Pulse Period	990ms ± 20ms
Positive Polarity Current consumption	35mA @ 33V
Reverse Polarity Current consumption	5uA @ 33V
Max Ripple Peak Voltage	2V
Operating Voltage Range	Regulated 16 VDC to 33 VDC
Operating Temperature	32° to 120° F (0° to 49°C)
Humidity Range	10% to 93%, non-condensing at 100° F (38°C)
Dimensions	114mm × 114mm × 29mm
Connections	Terminal for 18 AWG to 12 AWG (0.82 mm <sup>2</sup> to 3.31 mm <sup>2</sup> )
Mounting Box	4 × 4 inch Double Gang Box

**Product Specifications**

**DC IN:** VDOT-SFM main power input port, can be connected to the output of the NAC OUT FACP, or other independent power supply device. The DC IN input must be connected to a stable power supply.

When connected to the output terminal of the NAC OUT FACP, the forward polarity voltage will activate the module into alarm state, and the module does not work if a reverse polarity be added. The VDOT-SFM total current output capability is affected by the power supply output current, unless the power output capability is greater than the maximum output power of VDOT-SFM

**NAC OUT:** NAC OUT is a power supply with sync signal that provides power to audible devices, strobe device our audible / visual devices. A EOL resistance must be connected to the end of the loop when the loop works in Class B mode, the EOL resistance 4.7k Ohm (supplied).

**CLASS A IN:** VDOT-SFM supports Class A wiring mode, shown in figure 2 the loop through the appliances and back to EOL resistor in the VDOT-SFM.

**SYNC IN:** Synchronus signal input port, if the module is working in slave mode, its NAC OUT port is synchronisation with SYNC IN port. Maximum 8 x VDOT-SFMs connected together for multiple synchronised operation in same zone.

**SYNC OUT:** Sync signal output port for connecting to other VDOT-SFM devices or EOL resistance.

**HORN IN:** The HORN IN port is connected to the positive power, the NAC OUT output sync signal and power with audible activated, else the NAC OUT output sync signal and power with audible disabled.

**HORN OUT:** Connected to other VDOT-SFM devices or EOLR.

**VDOT-SFM STATUS:** VDOT-SFM detects the NAC OUT wiring fault or over current fault, then the VDOT-SFM output will output a signal if these fault occurred, the port is passive, it must be access by NAC Extender or other compatible equipment.

**Port Specifications**

**DC IN:** Input Power Voltage 16~33VDC, Maximum ripple peak voltage 2V, maximum current more than 4A, Maximum Reverse Voltage 40V

**NAC OUT:** Output Voltage 16~33VDC, maximum Total Continuous current Load 4A, EOL resistor 4.7k

**CLASS A IN:** Output Voltage 16~33VDC, maximum Continuous current Load 4A (same with NAC OUT), Built in EOL resistor 4.7k

**SYNC IN, HORN IN:** Same with SYNC IN and HORN IN.

**SYNC OUT, HORN OUT:** Same with SYNC IN and HORN IN.

**VDOT-SFM STATUS:** Open Collector Opto-coupler, maximum voltage 30V

**Port Specifications**

VDOT-SFM setting switch is located on the back of the product, shown in Figure 1, the setting modes and functional descriptions are listed in the following table:

Figure 1

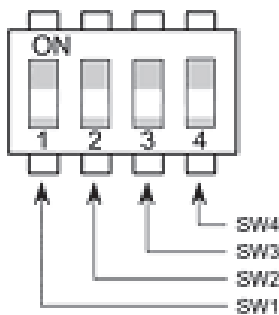

SW1	SW2			Functional Description
ON	ON			Reserved
ON	OFF			Continue
OFF	ON			Temporal 3
OFF	OFF			March Time
		SW3	SW4	Functional Description
/	/	ON	/	Slave
		OFF		Master
			ON	DC (no Sync Output)
			OFF	Sync Output

Note: SW1, SW2, and SW4 will be invalid if SFM is set to Slave mode (SW3 set to ON).

Wiring

Figure 2

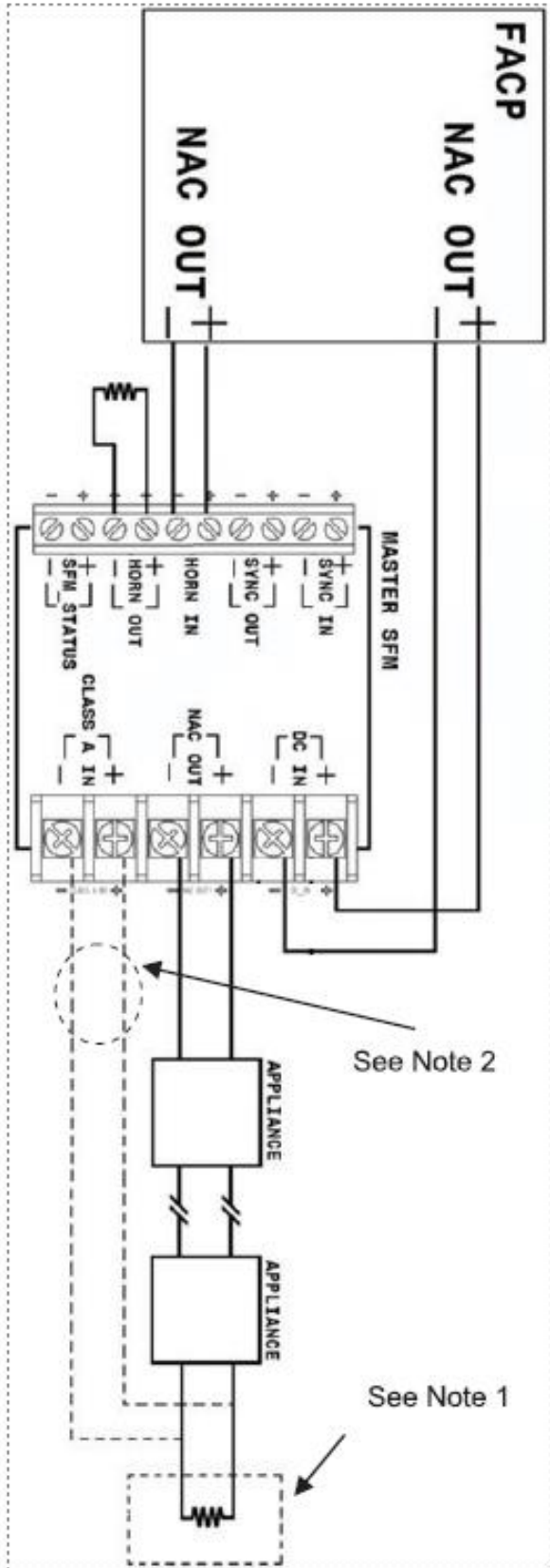

Figure 2. Typical Wiring Diagrams

Caution: VDOT SFM maximum total output capability is 4A, load current exceeds the maximum allowable current will cause VDOT-SFM damage or work abnormally.

**Note 1:** The resistance value is determined by the FACP NAC OUT, please check the FACP installation instructions.

The EOLR should be connected after the last device has been installed.

**Note 2:** The EOLR need not be added if the loop wiring in Class A mode, the EOLR has built in VDOT-SFM

Figure 3. Multiple Sync Wiring Instructions

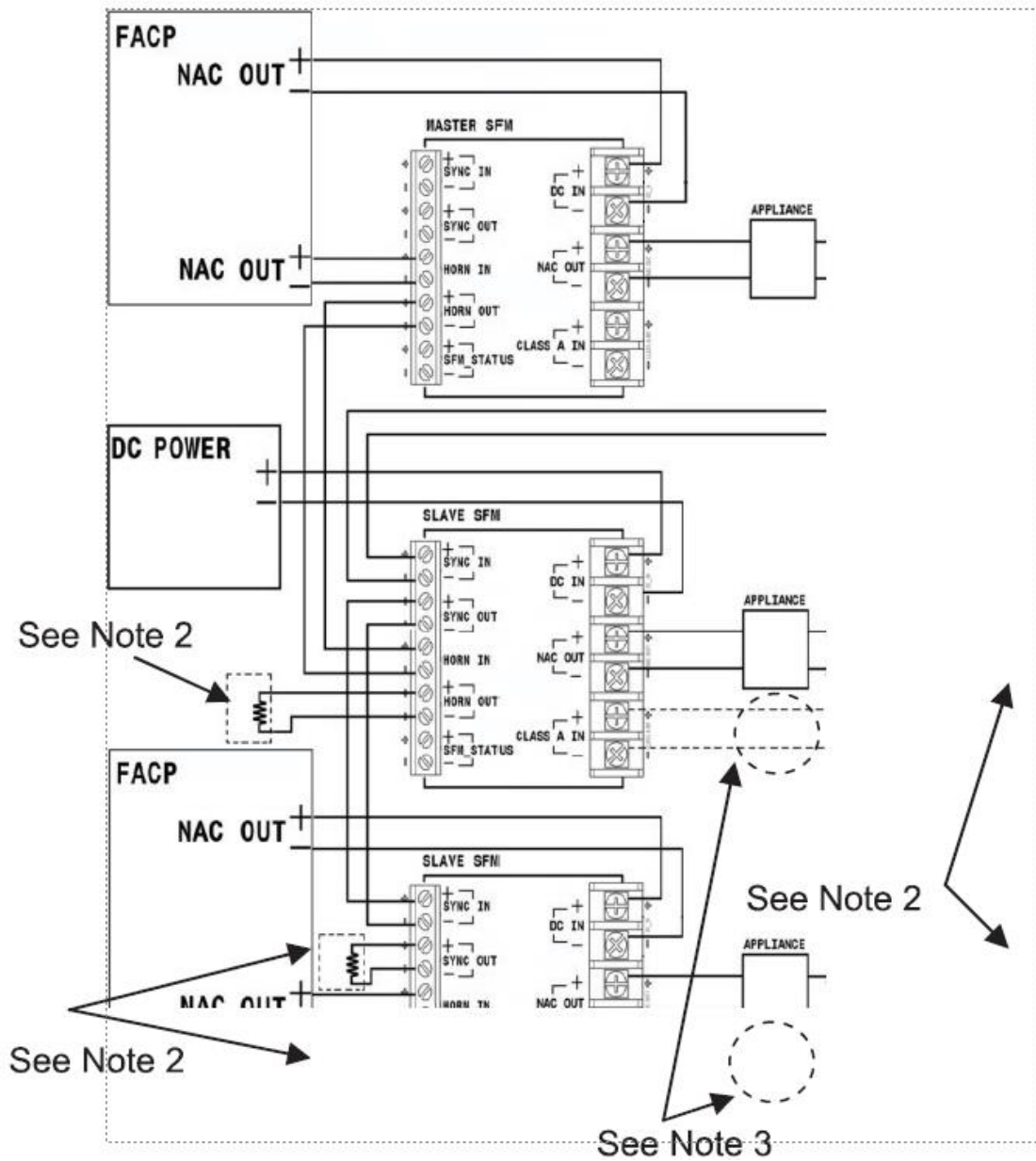

**Caution:** VDOT SFM maximum total output capability is 4A, load current exceeds the maximum allowable current will cause VDOT-SFM damage or work abnormally.

**Note 1:** Maximum 8 x VDOT-SFMs connected together for multiple synchronised operation in same zone.

**Note 2:** The resistance value is determined by the FACP NAC OUT, please check the FACP installation Instructions. **Important** - The EOLR should be connected after the last device has been installed.

**Note 3:** The EOLR need not be added if the loop wiring in Class A mode, the EOLR has built in VDOT-SFM.

**Note 4:** The diagrams shown in figure 3, all of the strobe devices are flashing synchronously, and the horn or other audible devices are determined by the polarity of the HORN IN ports.

## Mounting the VDOT-SFM

Figure 4

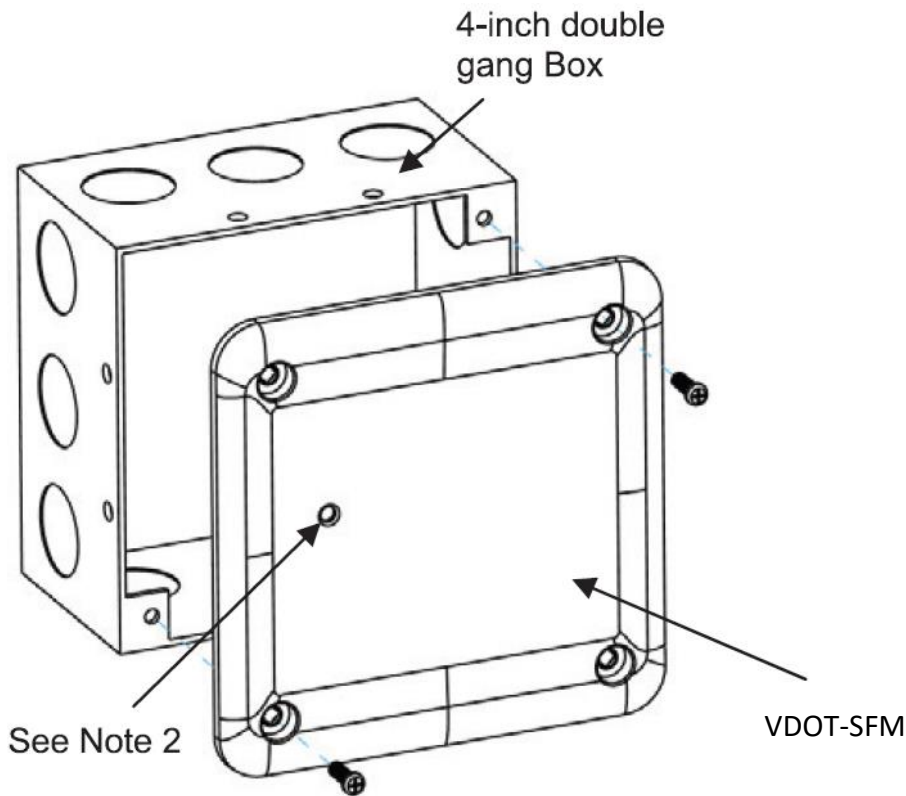

VDOT-SFM is installed on a 4-inch square electrical double gang box, the installation method shown in figure 4.

**Note 1:** The double gang box minimum depth required is 2 inches

**Note 2:** Working Status indicator

**Note 3:** Refer to the FACP Field Wiring Diagrams for detailed information on max wire run distances.

**Note 4:** Wire type 18-12 AWG

**Note 5:** Terminal T1 (DC IN, NAC OUT & Class A IN) maximum tightening torque: 0.5Nm (4.4Lb.in)