

## 1. Description

ZT-SD150 series Explosion-proof Sounder/Horn & Loudspeaker is designed according to EN / IEC60079-0, EN / IEC 60079-1 and EN 54 (SB 5879) standard.

Enclosure material is UV and corrosion resistance GRP (Glass Reinforced Polyester).

This product certified for use and installation in Zone 1 and Zone 2 areas with gases groups of IIA, IIB, IIC and temperature classification of T4-T6. The SD 125 version is made in SS 316 and the SD 150 version is made in GRP.

Users can choose single sounder, speaker or two-in-one sounder & loudspeaker. The design of two-in-one sounder & loudspeaker is unique.

According to user control system, 4 stages of alarm tones can be sent out. 63 tones are selectable.

Users can record sounds or customize sounds into the sounder by using 5 spare tones. Tone can be preset during installation.

## 2. Explosion Proof Labelling

All products have a rating label with the following important information:

**Product order no:** eg CP135SNNYNNABRD (Refer to the datasheet for product order selection)

**Input voltage:** up to 48V DC or 100-254V AC  
**Code:** SD150-1101400001  
Ex d IIC Txx Gb  
Ex tb IIIC Txx

**ATEX Mark:**  
**Gas Group and Category:** II 2GD  
**CE Mark:** Mark No: 0470

**Warning:** **DO NOT OPEN WHEN AN EXPLOSIVE GAS ATMOSPHERE IS PRESENT**

Finished product serial no: (include date of construction)

## 3. Type Approval Standard

The BC series products have been approved according the following standards:

IEC/EN 60079 General Requirements  
IEC/ EN 60079-1 Flame proof Enclosure 'd'  
IEC/ EN 60079-31 Dust atmosphere "t"

## 4. Zones, Gas Group, Category and Temperature

The BC series products have been certified Ex d IIC T4-T6. This means that the units can be installed in locations with the following conditions:

**Area Classification:**

- Zone 1:** Explosive gas air mixture likely to occur in normal operation.
- Zone 2:** Explosive gas air mixture not likely to occur, and if it does, it will only exist for a short time.

**Gas Groupings:** Group IIA Propane Group  
IIB Ethylene Group  
IIC Hydrogen and Acetylene

**Equipment Category:** ATEX, 2GD  
**EPL:** Gb/ Db  
**Temperature Range:** See label, ref page 1

## 5. Installation

**General Requirement**

Selection, Installation, Maintenance and repair of electrical apparatus for use in potentially explosive atmosphere should be done in according to IEC/ EN 6079-14/ -17/ -19. Product installation must be carried out in accordance with any local codes that may apply and should only be carried out by a competent electrical engineer.

**Location**

The location of the unit should be chosen with due regard to access. The unit should only be fixed to services that can support the weight of the unit.

**Mounting**

The product mounts to a 'U' shaped stainless steel its groove via a bracket by using one 12mm diameter and 2 x 8.5mm diameter bolt holes in the centre of the bracket. The alignment and positions can be adjusted by loosening the two M8 screws, which fastened the stainless steel bracket to the sounder. The sounder should be positioned such that dust, debris or water cannot enter into the horn opening.

Diagram 1

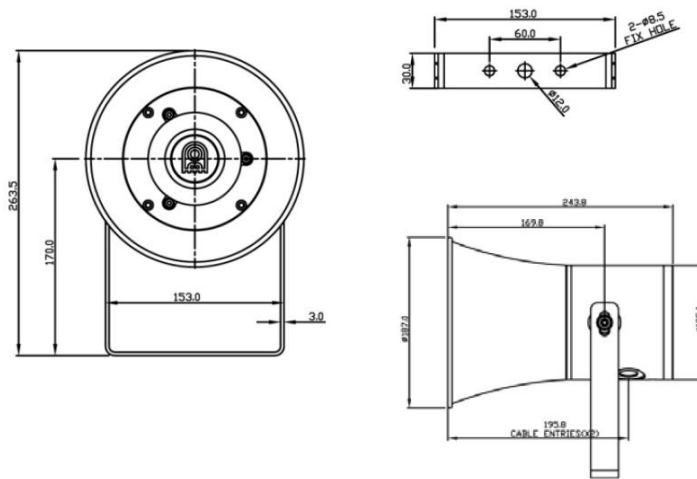

**6. Wiring**

**General Requirement**

We recommend that all cables and cores should be fully identified (suggest using cable from 2.0 to 2.5mm<sup>2</sup>). Ensure that all nuts, bolts and screws are secured. Ensure that only the right and certified cable glands are used and earthed correctly. Ensure that only the right and certified stopping plugs are used to blank off unused gland entry points. In order to maintain the IP rating of the product, we recommend SS316L for this application.

**7. Tone Selection**

The sounder provides 63 tones to be selected for the alarm stage 2 to 4. Three stages of alarm tones can be preset via switch on the Sounder PCB.

**Tone Selection Switch** - Use the three (3) DIP switches with 6 binary codes on the Sounder PCB to select tones (See Fig 3).

Tone Selection Table (see attached table 1)

Figure 3

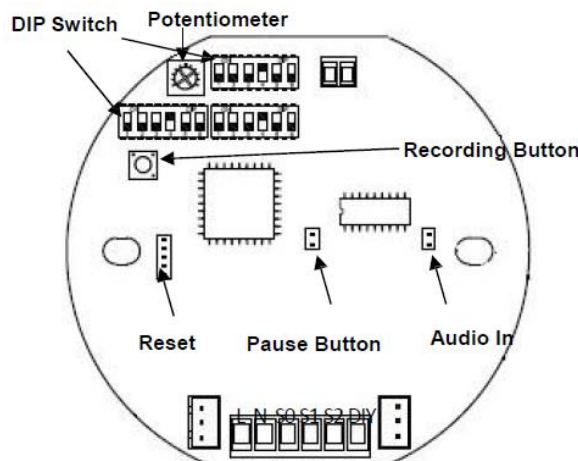

### 8. Volume Control

The sounder has a volume control to adjust the output volume of the sounder component. To set the required output volume, adjust the potentiometer-VR1 on the PCB (See Fig 3). The potentiometer should be set to fully clockwise position if maximum output volume is needed.

### 9. Sounder Recording

The sounder can provide 4 tones can be recorded by the user. Use the Audio In and Recording Button (See Fig 3) to record.

**Recording Procedure**

1. Turn off S1 and S2;
2. Set up any DIP Switches as Tone 60-63 (refer to attached Table 1- Tone Selection Table);
3. Insert the Audio IN plug;
4. Press the Recording Button and hold the button until the recording is finished.

**CAUTION:** The sounder will begin to record after 3 seconds from pressing the button. Don't release the button when the recording is in process. The maximum of recording time is 20 seconds.

### 10. Sound Base

The sound can pause by pressing the Recording Button.(See Fig 3)  
As the pausing period, please refer to the below table:

Pressing Times	Default Setting	Option
1	1 minute	10 minute
2	5 minute	30 minute
3	10 minute	60 minute
4	Restore to the sound	Restore to the sound

In order to have the option function, please inform us in advance before we begin the production of the sounder.

### 11. Cable Gland

The ZT-SD150 series product has cable gland entries. Only cable glands approved for Ex 'd' applications can be used, which must be suitable for the type of cable being used and also meet the requirements of the Ex 'd' flameproof installation standard EN/ IEC 60079-14.

**SAFETY WARNING:** If the SD150 is used at high ambient temperatures, i.e. over +40°C, then the cable entry temperature may exceed +70°C and therefore suitable heat resisting cable glands must be used, with a rated service temperature of at least 95°C. If a high IP (Ingress Protection) rating is required, a suitable sealing washer must be fitted under the cable gland. When only one cable entry is used, the other one must be closed with an Ex 'd' flameproof blanking plug.

### 12. End of Line Monitoring

An end of line monitoring diode or an end of line monitoring resistor can be connected across the 24V+ and 0 terminals. If an end of line monitoring resistor is used, it must have a maximum resistance value of 3k ohms and a minimum wattage of 0.5W ; or a minimum resistance value of 1.2k ohms and a maximum wattage of 2 Watts.

### 13. Maintenance

During working life of the product, little or no maintenance is required. GRP and ss 316 are resistant to most of the acids, alkalis and chemicals. If abnormal or unusual environmental conditions occur due to accident etc., visual inspection is recommended. If any failure occurs but not cause by human factor, the product can be returned using our returns policy

As to avoid electrostatic charge build-up, only exterior of the product can be cleaned with a damp cloth. If spare parts are required, these can be supplied by us

**SAFETY WARNING:** In the case of Anti- Static and UV Resistant GPR and SS 316, the painting of the enclosure surface has been processed specially. To maintain the product to be Anti-Static, extra normal painting is not allowed.

## 14. Conditions of Safety Use

- i. This apparatus is suitable to be used only in ambient temperature as stated at the label
- ii. Other than product manufacturer, painting and surface finishing are not permitted by the third party.
- iii. When used in dust atmosphere, flameproof cable entry devices or stopping plugs have to be selected and installed carefully in order to maintain the IP rating (IP66/67) of the product.

### Specific Condition for Use

Repairs of the flameproof joints must be made in compliance with the structural specifications provided by the manufacturer. Repairs must not be made on the basis of values specified in tables 1 and 2 of EN/ IEC 60079-1.

Attached Table 2:  
Tone Selection Table

ITEM	DESCRIPTION				Max dB	SW1,SW2,SW3,SW4
Tone	Frequency	Tone Description	Tone Application	Waveform	(DB)@1M	Bit 123456
0	0	0	0	0	0	000000
01	300Hz	Continuous			105	100000
02	340Hz	Continuous			105	010000
03	440Hz	Continuous			105	110000
04	554Hz	Continuous			106	001000
05	660Hz	Continuous	All-clear, Sweden		104	101000
06	800Hz	Continuous			105	011000
07	1000Hz	Continuous	PFEER Toxic Gas		109	111000
08	1200Hz	Continuous			106	000100
09	2000Hz	Continuous			105	100100
10	2400Hz	Continuous			103	010100
11	2850Hz	Continuous			102	110100
12	420Hz@0.625 sec	intermittent	Australian, AS2220		100	001100
13	544Hz@0.875 sec	intermittent			104	101100
14	660Hz@150ms on,150ms off	intermittent	Swedish Fire Alarm		100	011100
15	660Hz@1.8sec on,1.8sec off	intermittent	Swedish Fire Alarm		103	111100
16	745Hz@500ms on,500ms off	intermittent			102	000010
17	800Hz@250ms on,250ms off	intermittent			102	100010
18	800Hz@250ms on,1sec off	intermittent			100	010010
19	1000Hz@250ms on,250ms off	intermittent			105	110010
20	1000Hz@500ms on,500ms off	intermittent	Back-up Alarm(LF)		105	001010
21	1000Hz@250ms on,1sec off	intermittent			105	101010
22	1000Hz@1sec on,1sec off	intermittent	PFEER Gen, Alarm		105	011010
23	2400Hz@250ms on,250ms off	intermittent			101	111010
24	2400Hz@500ms on,500ms off	intermittent			100	000110
25	2850Hz@1sec on,1sec off	intermittent	Back-up Alarm(HF)		101	100110
26	2850Hz@150ms on,100ms off	intermittent	Pelican Crossing		101	010110
27	970Hz@0.5sec on/0.5sec off,1.5sec off	3 Pulses	ISO 8201 Low tone		105	110110
28	2850Hz@0.5sec on/0.5sec off,1.5sec off	3 Pulses	ISO 8201 Low tone		101	001110
29	700Hz@2sec on/2sec off	intermittent	Air-raid, Sweden		105	101110
30	700Hz@125ms on/125ms off	intermittent	Local warning, Sweden		105	011110
31	720Hz@0.7sec on/0.3sec off	intermittent	Industrial alarm, Germany		105	111110
32	544Hz/440Hz@500ms	Alternating	Swedish Fire Alarm		101	000001
33	544Hz/440Hz@100ms/400ms	Alternating	AFNOR,NFS 32-001		101	100001
34	544Hz/440Hz@1sec	Alternating	Turn-out, Sweden		100	010001
35	800Hz/1000Hz@125ms	Alternating	Increased Urgency		104	110001
36	2400Hz/2900Hz@125ms	Alternating	Security Deterrent		100	001001
37	800Hz/1000Hz@250ms	Alternating	Fire Alarms		104	101001
38	800Hz/1000Hz@580ms	Alternating			104	011001
39	1000Hz/2000Hz@500ms	Alternating			104	111001
40	2400Hz/2900Hz@250ms	Alternating	Security Alarms		100	000101
41	500Hz-1000Hz@6Hz	Fast whoop			103	100101
42	500Hz-1200Hz@0.3Hz	Sweeping			102	010101
43	660Hz-1200Hz@1Hz	Sweeping			101	110101
44	800Hz-1000Hz@1Hz	Med Sweeping(LF)			101	001101
45	800Hz-1000Hz@7Hz	Fast Sweeping(LF)			102	101101
46	2400Hz-2900Hz@1Hz	Sweeping			100	011101
47	2400Hz-2900Hz@7Hz	Fast Sweeping			100	111101
48	800Hz-1000Hz@50Hz	Low Freq Buzz	Buzz		100	000011
49	2400Hz-2900Hz@50Hz	High Freq Buzz	Buzz		100	100011
50	500Hz-1200Hz@2.5sec↑ 0.5sec	Slow Whoop			102	010011
51	500Hz-1200Hz@5sec↑ 0.25sec	Slow Whoop	Evacuation,Netherlands		102	110011
52	1200Hz-500Hz@1Hz	Reverse sweeping	Evacuation,Germany		102	001011
53	1400Hz-1600Hz@1sec↑, 0.5sec↓	sweeping	NFC 48-265		100	101011
54	Simulated Bell	Fast Shake	Bell		98	011011
55	800Hz/660Hz	Tow tone chime	Int'l evacuation alarm		102	111011
56	800Hz/1000Hz	ISO 8201 Evacuation	Int'l evacuation alarm		102	000111
57	250Hz-1200Hz@3sec↑, 6sec 3sec↓	Motor Siren-slow rise			104	100111
58	250Hz-800Hz@3sec↑, 6sec 3sec↓	Motor Siren-slow rise			105	010111
59	250Hz-2400Hz@6sec↑, 6sec 6sec↓	Motor Siren-slow rise			100	110111
60	Client Spare recording					001111
61	Client Spare recording					101111
62	Client Spare recording					011111
63	Client Spare recording					111111

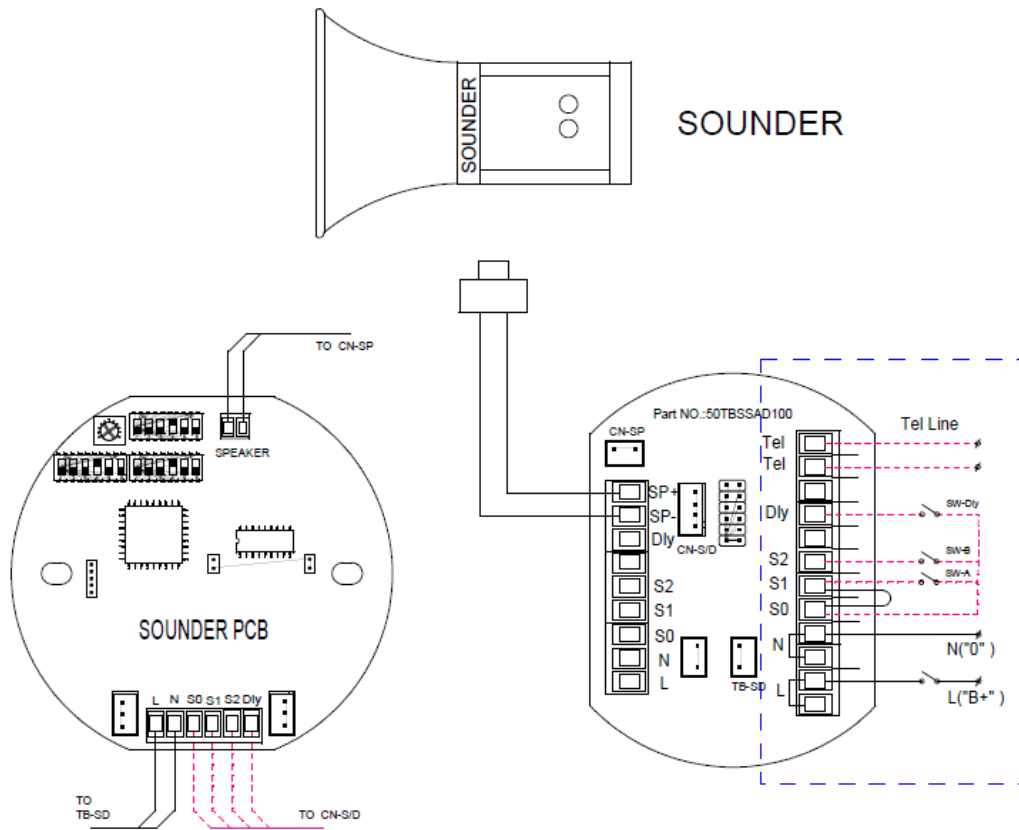

Wiring For Customer

**Wiring Method**

Factory default settings

1. S0 and S1 are connected (default stage 1 alarm output).
2. Connect power supply line to terminals "L" and "N". If power supply is DC. "L" presents "+". "N" presents "0".
3. The unit will alarm (default stage 1 alarm output) when power is on.

**Three stages alarm output settings**

1. Connect power supply line to terminals "L" and "N". If power supply is DC. "L" represents "+". "N" represents "0".
2. Connect S1 to S0 for stage 1 alarm output  
Connect S2 to S0 for stage 2 alarm output  
Connect S1\S2 to S0 for stage 3 alarm output
3. The unit won't alarm when power is on.
4. The unit will alarm as stage 1 when switch 1 is on.  
The unit will alarm as stage 2 when switch 2 is on.  
The unit will alarm as stage 3 when switches 1/2 are on.

**Telephone Initiated PCB Function**

1. Connect the telephone line to the "Tel" terminals.
  2. The unit will alarm when telephone rings.
  3. The unit will stop alarming when the telephone handset is picked up.
- Please refer to our product technical manual for more details.

**Cable Selection**

Please select suitable size cable according to the distance between control room & the terminals and the quantity of equipments used.

Normal size for AC power supply cable L & N is 1.5mm<sup>2</sup>. Normal size for DC power supply cable L & N is 2.5mm<sup>2</sup>.

Please select the quantity of control cables (0 to 4) according to the actual requirement. Normal size for control cable is 1mm<sup>2</sup>.

**Limited Warranty**

Velocity declares that this product is free from defects in material and workmanship, and it will repair or replace any product or part thereof which proves to be defective in workmanship or material for a period of twelve (12) months from the date of purchase but not to exceed eighteen (18) months from the date of manufacture.

Please contact Velocity Detection over Time directly for a return. A merchandise authorization (RMA) number must be requested from us before returning goods under warranty. Shipment must be prepaid and Velocity Detection over Time will repair or replace the product if the failure was caused by a manufacturing defect.