

1. Description

The ZT-CP135 range is certified for use and installation in Zone 1 and Zone 2 with gas groups IIA, IIB+H2 also Zones 21 and 22 for Dust. The unit carries a temperature classification of T4-T6. It especially applies to Oil & Gas, Offshore Platform, Chemical, Petrochemical, Refinery and Marine Industries etc.

Enclosure material is UV and corrosion resistance GRP (Glass Reinforced Polyester). The manual call point has been designed for ease of installation and operation.

These call points are compatible for use with PLC, DCS & ESD systems via a 4-20mA output. They are intended for use in Fire Alarm Systems as a fixed addressable unit in potentially explosive atmospheres.

There are three types of Manual Call Points available with LED indication.

- **Red LED Indicator Only:** During normal operation the LED will not be on.
The LED will only come on when the call point is activated by breaking the glass.
- **Green LED Indicator Only:** During normal operation the LED will be on.
The LED will go off when the call point is activated by breaking the glass.
- **Red & Green Indicators:** During normal operation the Green LED will be on.
The Red LED will come on when the call point is activated by breaking the glass.
At this point the Green LED will go off.

2. Explosion Proof Labelling

All products have a rating label with the following important information:

Product order no: eg CP135SNNYNNABRD (Refer to the datasheet for product order selection)

Input voltage: <30V DC / 6A or <250V AC / 11A Ex d IIB
Code: +H2 T6 Gb, Ex tb IIIC T850C

Nemko ATEX Certificate No: Nemko 13ATEX 1568X

ATEX Mark:
IECEx Certificate: IECEx-NEM 13.0038X
Gas Group and Category: II 2GD
CE Mark: Mark No: 0470

Warning: **DO NOT OPEN WHEN AN EXPLOSIVE GAS ATMOSPHERE IS PRESENT**

Finished product serial no: ie. ZT-CP135-110140001
ZT-CP135- GRP Manual Call Point: 110- France, 14- Year, 0001- Product serial number

3. Type Approval Standard

The Zeta Alarms product range all have an EC Type Examination Certificate issued by Nemko and have been approved to the following standards:
EN 60079-0:2012 (IEC 60079-0:2011), EN-60079-1:2007 (IEC 60079-1:2007) EN 60079-31:2009 (IEC 60079-31:2008)

4. Zones, Gas Group, Category and Temperature

The ZT-CP135 series products have been certified Ex d IIB+H2 T6.
This means that the units can be installed in locations with the following conditions:

Area Classification:

- Zone 1:** Explosive gas air mixture likely to occur in normal operation.
- Zone 2:** Explosive gas air mixture not likely to occur, and if it does, it will only exist for a short time.

Gas Groupings: IIB+H2.

- Zone 21:** Explosive dust air mixture likely to occur in normal operation.
- Zone 22:** Explosive dust air mixture not likely to occur, and if it does, it will only exist for a short time.

Equipment Category: 2GD
Temperature Range: -400C < Ta <+700C

5. Installation

General Requirement

The product must be installed in accordance with the latest EN60079-0 and EN60079-1 specification or the equivalent IEC specification. Product installation must be carried out in accordance with any local codes that may apply and should only be carried out by a competent electrical engineer.

Location

The location of the unit should be chosen with due regard to access. The unit should only be fixed to services that can support the weight of the unit.

Mounting

The product should be mounted on a vertical surface using four fixing holes in the base. The fixing holes are designed to fit M5 Allen Screw only. Use of stainless-steel fasteners is recommended. The unit can be operated in any attitude. If you need a mounting plate, please contact us to ask for the mounting plate installation drawing (see diagram 1).

Diagram 1

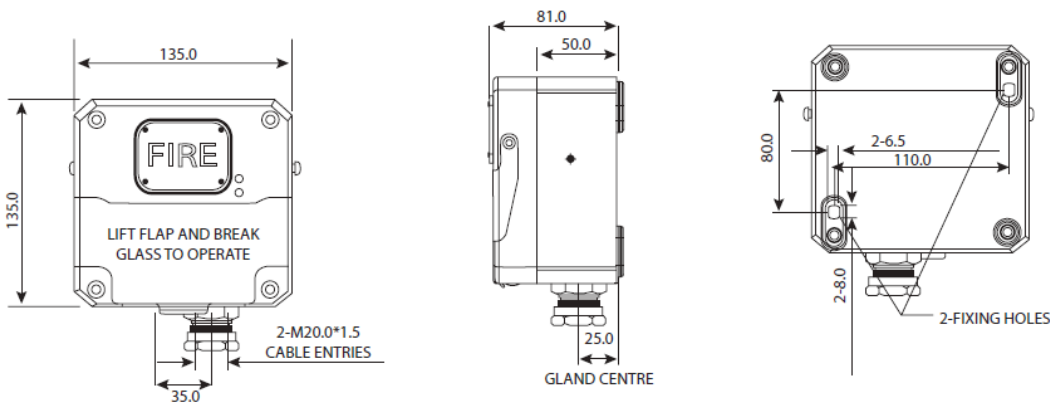

6. Wiring

General Requirement

We recommend that all cables and cores should be fully identified (suggest using cable from 2.0 to 2.5 mm²). Ensure that all nuts, bolts and screws are secured. Ensure that only the right and certified cable glands are used and earthed correctly. Ensure that only the right and certified stopping plugs are used to blank off unused gland entry points.

Cable Connection

The cable connection is made to the 10-hole terminal block marked T1-T10 inside the enclosure (see diagram 2). Cable connection should be carried out in accordance with relevant technical requirements.

Remove Front Cover

CAUTION: Before removing the cover, ensure the power to call point is isolated. Unscrew the four (4) M5 retained Hex Head socket screws to open the cover.

Note: it recommended to open one blind plug to avoid internal vacuum in the unit

This will release the cover from the base and allow the cover to hang on the retaining wire strap. Before replacing the cover, check that the flameproof joints are clean and not damaged, the gasket is still retained in its groove (see diagram 2).

As lubrication / grease for the flameproof joint, a thin film of Acid free Vaseline (soap-thickened mineral oils) or mineral oil can be used, excessive lubrication/grease shall be removed before assembling.

Reinstall the cover in similar way, but operate in reverse manner as above.

Recommended Bolt Torque for M5 lid screws are 4.5Nm

Diagram 2

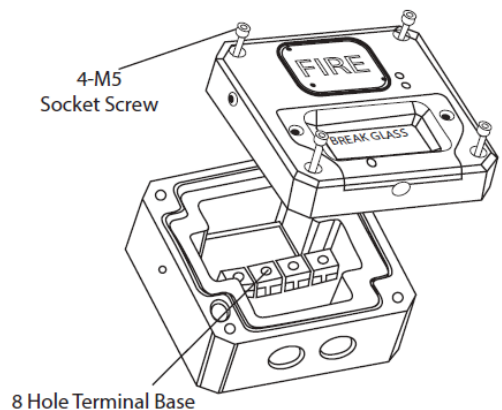

7. Operation

In this model series, the units either come with a hinged flap (to prevent accidental activation of the unit) or no hinged flap.

In either case the glass must be broken with the hammer supplied with the unit to activate it (see diagram 3).

Replacement of Glass

To replace the glass after operation of the unit, remove the small cover held in place by the two slotted screws. Take out the glass and remove any broken fragments from the unit. Place a new glass into the unit and replace the cover. (see diagram 3).

Testing the Unit

Insert the test key facility to the keyhole located in the lower left corner of the cover. Then turn the key clockwise. The glass sheet will drop. This will simulate the breaking of the glass.

Turn the key anti clockwise to reset the unit.

Diagram 3

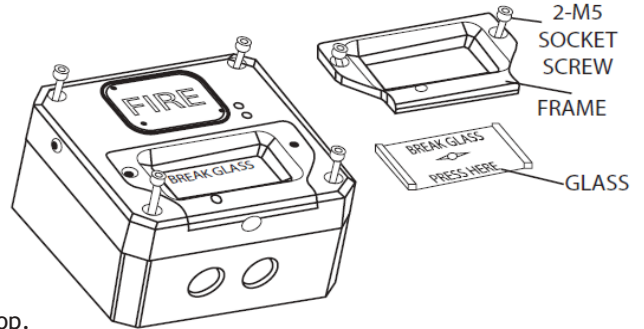

8. Cable Gland

Only cable glands approved for Exd applications can be used with our Explosion Proof Products, these must be suitable for the type of cable being used and also meet the requirements of the Exd flameproof installation standard EN 60079-14.

SAFETY WARNING

If units are used at high ambient temperatures, i.e. over +400C then the cable entry temperature may exceed +700C and therefore suitable heat resisting cable glands must be used, with a rated service temperature of at least 850C.

If a high IP (Ingress Protection) rating is required, a suitable sealing washer must be fitted under the cable gland. Any unused cable entry holes must be closed with an Exd flameproof blanking plug, which must be suitably approved for the installation requirements.

9. End of Line Monitoring

An End of Line monitoring Diode or an End of Line monitoring Resistor can be connected across the 24V+ and 0 terminals. Resistor values for the End of Line will be determined by the customer with a minimum value of 1.2kΩ

10. Maintenance

Little or no maintenance is required during the normal working life of the product. The Exd enclosures are resistant to most acids, alkalis and chemicals and have been designed to withstand severe weather conditions. However, it is suggested that to avoid the possibility of a potential electrostatic charge build up, the exterior of the product is periodically wiped down with a clean damp cloth. At this point a visual inspection is recommended to ensure that the product is in good working order and no damage has been sustained during its normal operation.

11. Conditions for safe usage

This apparatus is suitable to be used only in ambient temperature as stated below:

| Type | Ambient Temp |
|-------|----------------|
| CP135 | -40°C to +70°C |

Do not paint or change the surface finish of the unit. The coating applied by the manufacturer is Anti-Static & UV Stable.

Specific Condition for Use

Repairs of the flameproof joints must be made in compliance with the structural specifications provided by the manufacturer. Repairs must not be made on the basis of values specified in tables 1 and 2 of EN/IEC 60079-1.

Limited Warranty

Velocity Detection declares that this product is free from defects in material and workmanship, and it will repair or replace any product or part thereof which proves to be defective in workmanship or material for a period of twelve (12) months from the date of purchase but not to exceed eighteen (18) months from the date of manufacture.

Please contact Velocity Detection over Time directly for a return. A merchandise authorization (RMA) number must be requested from us before returning goods under warranty. Shipment must be prepaid and Velocity Detection over Time will repair or replace the product if the failure was caused by a manufacturing defect.